

To the Purchaser:

This Manual contains valuable information about your NORTHWEST ROTARY TILLER. In this Manual you will find instructions and helpful suggestions for operating, attaching, adjusting, and assembling your new Rotary Tiller.

Keep this Manual in a convenient place for quick and easy reference. Use it as a guide whenever questions arise. You have purchased a dependable, sturdy machine, but only by proper care and operation can you expect to receive the service and long life designed and built into it.

We have endeavored to build a Rotary Tiller with the strength and durability to fit present day larger tractors and modern farming practices. At the same time we have tried to eliminate excessive weight to allow its use integrally hitched to most tractors.

In any powered ground working implement such as this, some means must be provided to protect the tractor and implement gear train (shafts, bearings, gears, universal joints, etc.) as well as the cutting blades.

We have found multiple "V" belt drive, incorporating the automatic belt tensioning idler system, the simplest, most "fool-proof" and effective answer to this problem.

With just reasonable care these belts will give long life and still slip or stretch upon the tiller encountering large rocks, roots, etc., thereby protecting both tiller and tractor (See Page 5 and 6).

Please Fill Out Below For Your Records.

Serial # of this Tiller is: **RB7934** \_\_\_\_\_

Model #: **DD HC 168 SC SOD** \_\_\_\_\_

Date purchased: \_\_\_\_\_

# WARRANTY

Northwest Tillers, Inc., warrants its products to be free of defects in workmanship and material for a period of 90 days from the date of delivery to initial user when given reasonable use under normal conditions. This warranty is limited to the repair or replacement, as the manufacturer shall elect upon inspection to have been defective in material or workmanship, but does not include any installation or transportation costs.

This warranty shall not apply to any Northwest Tiller equipment, or part thereof which has been damaged in any accident, by fire, flood, or act of God. This warranty is likewise not extended to repairs on second hand machines, nor to Northwest products on which repairs or alterations have been made, or when other than Northwest Tiller equipment parts have been used, unless authorized in writing by the manufacturer.

The manufacture reserves the right, at any time, to make changes in design, materials or specifications of its products, without thereby becoming liable to make similar changes in units manufactured earlier.

This warranty is in lieu of all other warranties covering Northwest products and no other warranties expressed or implied are made or authorized by the manufacturer.

**NORTHWEST TILLERS, INC.  
P.O. BOX 10932  
YAKIMA, WASHINGTON 98909 U.S.A.**

**Note: For this equipment to be covered by above warranty, the factory must have on file all information asked for in postcard attached to inside front page.**

**Note: All warranty work must be authorized by factory representative.**

## Attaching Tiller to Tractor

CHECK DECALS  
CAREFULLY  
for greasing and  
adjustments

DO NOT BACK UP THE TILLER  
when in working position, a bent  
Apron or Damage to belts may occur.

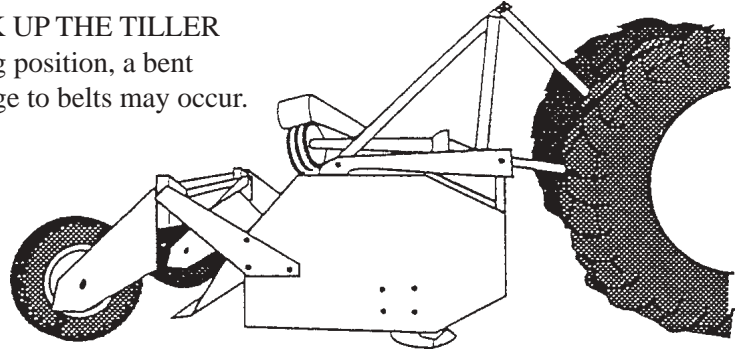

Tiller fits either #1 or #2 Category tractor hitches with no extra parts.

The Model "B" Tiller Hitch connects with either Category #1 or #2 linkage and the PTO Shaft Assembly fits most standard 3 point hitch tractors.

Before operating in the field it is best to check the PTO shaft length in both the raised and lowered positions on integral hitch tractors so that it neither bottoms (32 1/2" overall) nor extends beyond 43" overall.

The driveline fits together so that the yokes on the center sections are always in line. Should the assembly ever be changed or damaged, always check to be sure that this alignment is retained since out of alignment will cause pulsating of the drive line.

Stabilizer bars on the tractor hitch are desirable.

Always adjust top link so tiller frame is "level" when in working position.

When first attaching to tractor, lift tiller carefully to determine that (1) PTO Universal Assembly does not strike frame; (2) telescoping shaft does not bottom. If either occurs, hydraulic lift adjustment on tractor must be set to reduce height of lift.

To prevent damage to Gauge Wheels, Aprons, and Blades, be sure tractor hydraulic lift is set to drop slowly.

When first operating tiller it is best to set the Gauge Wheels for shallower work than will be desired to allow for short "breaking in" period. To best determine depth of cut stop tractor but allow tiller to operate for a few moments, then raise and drive ahead. A clean "furrow" will appear, which may then be accurately measured.

**Assembly Bulletin No. 401**

**Assembled view of Northwest Rotary Tiller with Mesh Roller**

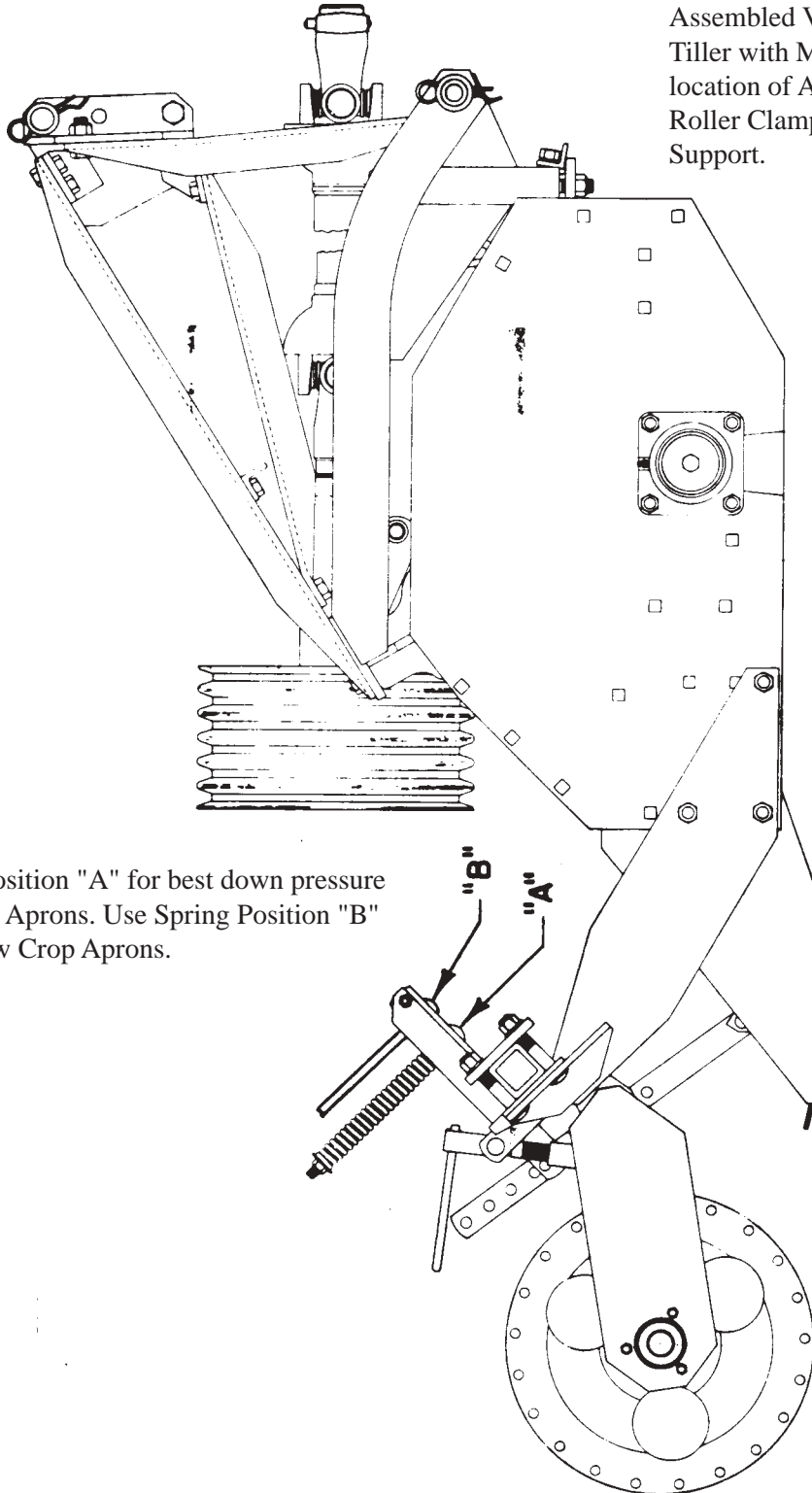

Assembled View of Northwest Rotary Tiller with Mesh Roller showing proper location of Apron Hold Down and Mesh Roller Clamps attached to the Rear Bar Support.

Use Spring Position "A" for best down pressure on Full Width Aprons. Use Spring Position "B" for hte Narrow Crop Aprons.

**Model "RB" Tiller - Bedder Assembled View**

Assembly Bulletin No. 403

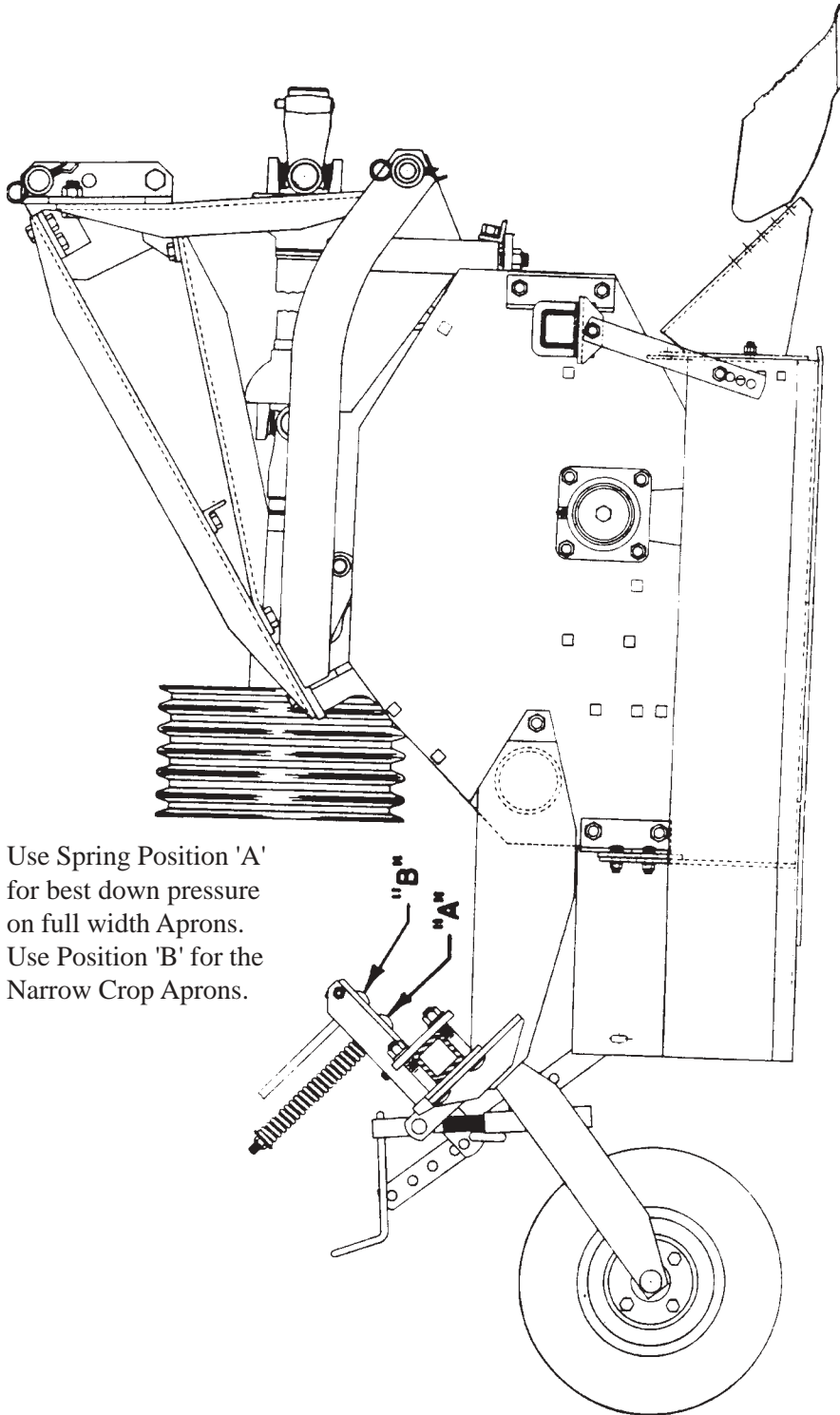

Use Spring Position 'A' for best down pressure on full width Aprons. Use Position 'B' for the Narrow Crop Aprons.

Factory does not furnish the furrower. Any standard wing type or flat furrower may be attached.

When used with tractors with insufficient lift and transport stability the RB-4088 or RB-4089 Hydraulic Lift Assist gauge wheels may be added.

For narrow bottom furrows (up to 9") use RB-4098 gauge wheels. For wider furrow bottoms use either RB-4070 or RB-4099 gauge wheels.

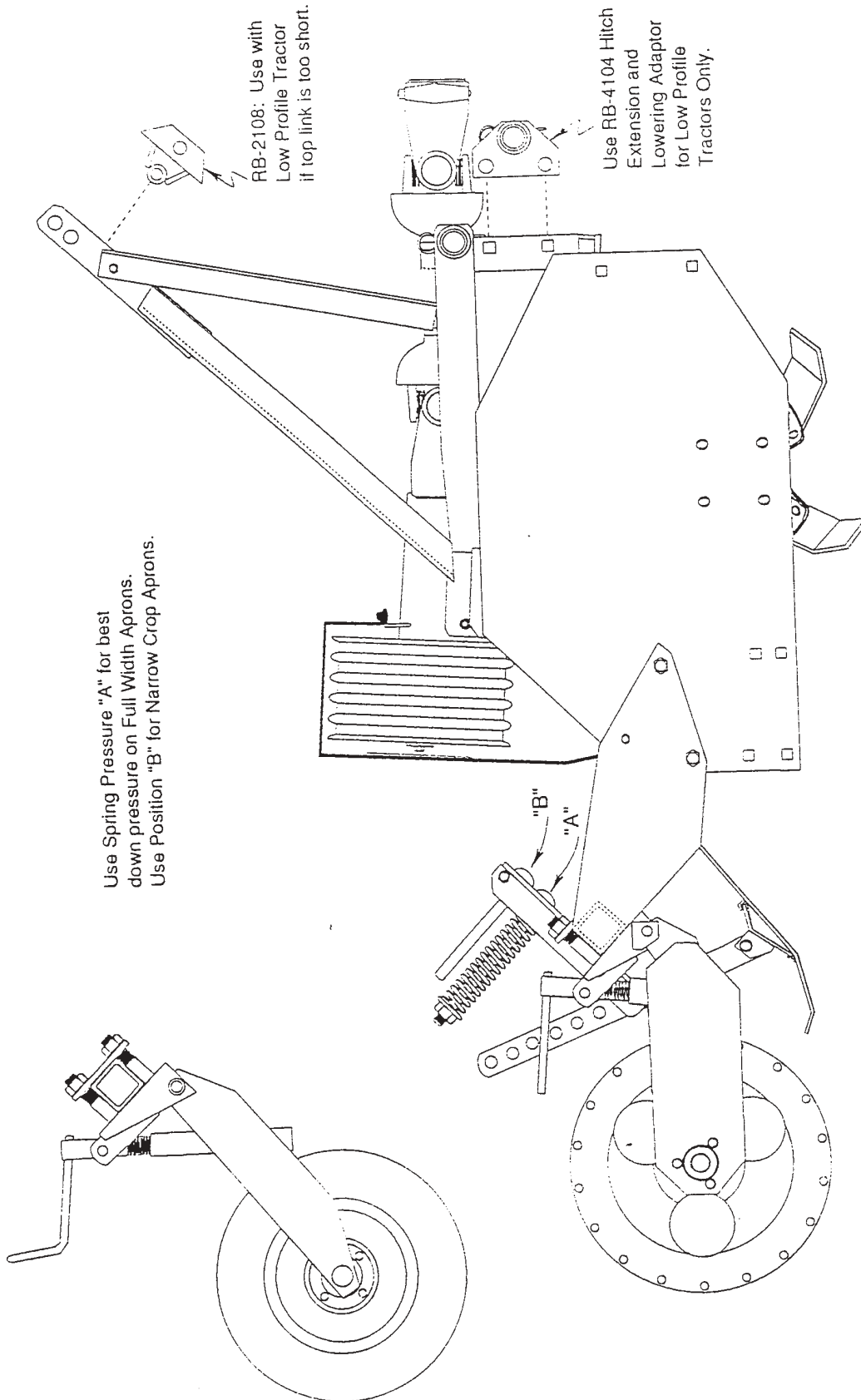

Assembled View of Northwest's Standard Duty Rotary Tiller with Gauge Wheels or Mesh Roll showing proper location of Apron Hold Down and Gauge Wheel Clamps attached to Rear Square Bar.

## Rotor & Blade Assembly For Regular "flat" blades

See pages 3.2 & 3.3 for Saber or Stub Blades

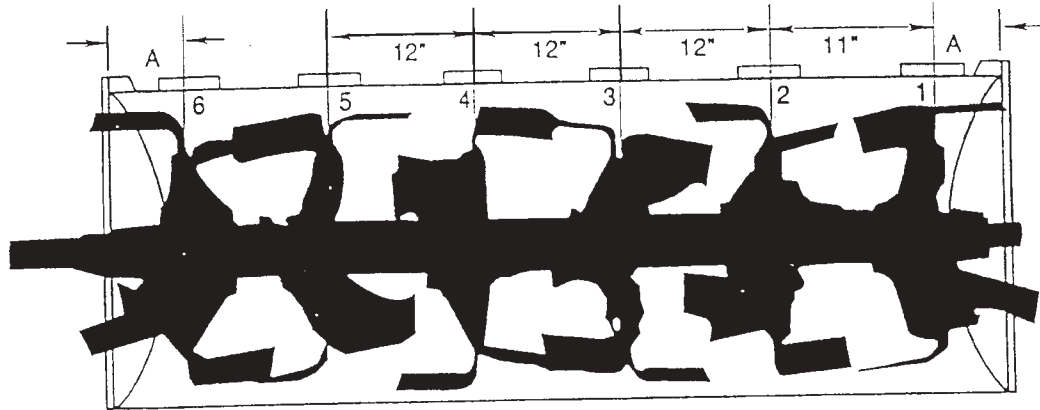

Figure 1

For convenience a 6' Rotary Tiller is shown above but instructions apply to other width Tillers except dimension "B" which can be found on chart at end of instructions.

**This arrangement applies to Rotors R-50, RB-42-44, RB-62-64, D-150, and all welded rotors.**

Should it be necessary to re-assemble rotors and blades, the following instructions should be carefully followed to avoid confusion in attempting to achieve the proper blade and rotor spiral.

We suggest that the Tiller be tipped on its "face" with the mast forward for easy handling.

1. Starting at the R.H. end and working from the rear of the Tiller, place 2-Blade Rotor Half in position on top of rotor shaft with hub pointing to left (See 1, Figure 1). Attach 4-Blade Rotor Half in position on under side of  $3/4$ " carriage bolts placed down through the upper half. Tighten into place with vertical center of blade approx. 7" from inner face of housing (See Figure 1). NOTE: R-50 & D-150 Rotor Halves are identical, but the reference, bolts are placed downward as above. We should remind you to always place bolts downward through each upper Rotor Half for easy checking of relative Rotor position.
2. Rotate shaft  $1/4$  turn forward (top-edge of Rotor or Blade would turn away from you) and repeat instruction #1 except to locate per dimension shown in Figure 1.
3. For the remaining Rotors repeat instruction #2, that is turn Rotor Shaft ahead  $1/4$  turn and secure as described. On all other width Tillers, these center Rotors are spaced as above.
4. For the last Rotor repeat instructions #2 and #3 except face the hub to right (away from the housing) setting blade face approximately 7" from inner face of housing. It is best to strike rotor bolt heads with a heavy hammer and re-tighten securely in all rotors to avoid loosened bolts. (See #5 for change in blade arrangement for this Rotor).

## Rotor & Blade Assembly...Continued

5. Blades may either be assembled in rotors in advance or after rotors are placed as above. Remember that blades are attached to ALL rotors in the same position and sequence except the last rotor installed or the L.H. end rotor, with hub of rotor facing you as in picture (See figure 2). Place a R.H. blade in position 1, a L.H. blade in position 2, a R.H. blade in position 3, etc. On the last rotor or the left end rotor, simply reverse this procedure. (Place a L.H. blade in position 1, a R.H. blade in position 2, a L.H. blade in position 3, etc.) This assembly should give a "spiral" as shown.

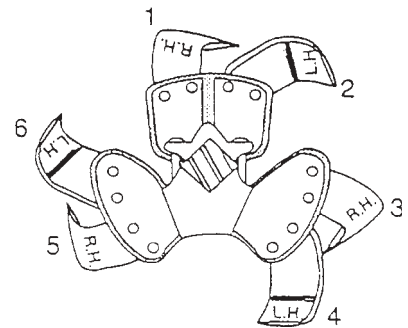

Figure 2

**Remember: ALL rotor blade assemblies should appear alike (as shown in figure 2) EXCEPT L.H. rotor.**

## Rotor & Blade Assembly For Saber and Stub Blades

See pages 3 & 3.1 for Regular Flat Blades

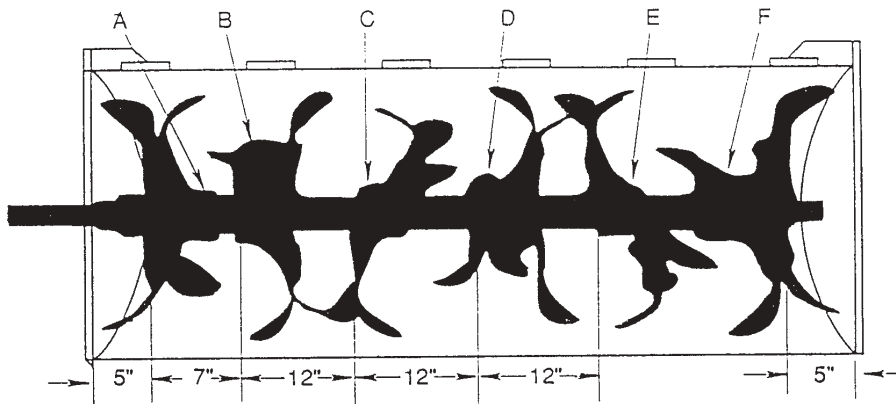

Figure 1

1. Starting with the L.H. Rotor Assembly A, Figure 1, with blades assembled as in figure 2, place a 2-Blade Rotor Half in position on top of shaft, hub of rotor to right and face of blade approximately 5" from inside of housing end. Insert 3/4" carriage bolts with heads up and attach 4-Blade Rotor Half with hub to right as shown. Tighten in place.
2. Rotate shaft 1/4 turn backward (top blades toward you). Again place a 2-Blade rotor Half into position B, Figure 1, with hub to your right.

**NOTE:** All Rotor Assemblies except A, have blades assembled as in figure 3. Place 3/4" carriage bolts as above. Attach 4-Blade Rotor Half, but with hub to your left. See Figure 3. Fasten in place with c-c of blades on the 2-Blade Rotor Halves approximately 7".

3. Again rotate rotor shaft 1/4 turn backwards. Place 2-Blade Rotor Half into position C. Complete assembly exactly as in #2, except space 2-Blade Rotor Halves at 12" c-c of blades.
4. For D, E, & F repeat #3, except fasten last assembly F with face of blade approximately 5" from inside of housing.

**Remember:** Rotor Assembly A is arranged as in figure 2. All other rotors have the same blade arrangement as in Figure 3. Always measure spacing of only the 2 Blade Rotor Halves. For wider Tillers proceed as above with additional Rotor assemblies.

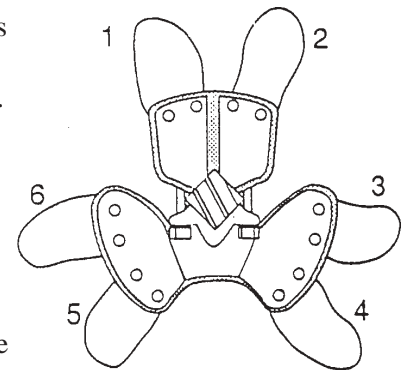

Figure 2

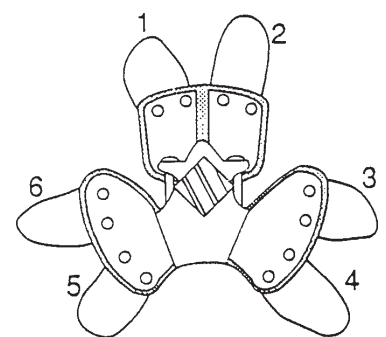

Figure 3

## Blade Assembly

Blades may either be assembled in rotors in advance or after rotors are positioned as described. Blades for position A are assembled as in Figure 2, with L.H. blade at 1, a R.H. blade at 2, a L.H. blade at 3, etc. All other Rotor Assemblies have blades assembled as in Figure 3, with a L.H. blade in position 1, a R.H. blade at 2, etc.

## Spike Rotor & Blade Assembly

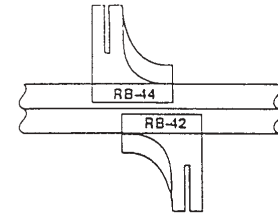
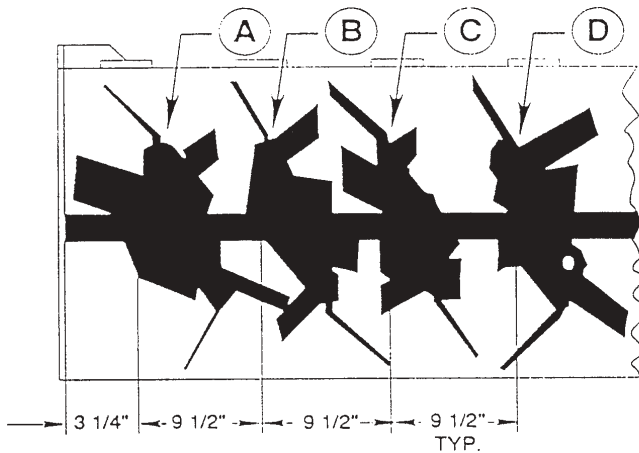

Figure 1  
All rotors are mounted in this manner - from left to right.

1. Starting with the L.H. Rotor Assembly **A**, with blades assembled as in figure 2, place a 4-Blade Rotor Half (RB-44) in position on top of the shaft (hub of rotor to right) and center of rotor approximately 3 1/4" from inside of housing end. Insert 3/4" carriage bolts with heads up and attach 2-Blade Rotor Half (RB-42) as shown in figure 1. Tighten into place.
2. Rotate shaft 1/2 turn backward (top blade toward you) and position 4-Blade Rotor Half (RB-44) **B** with blades assembled as in Figure 3. (Hub of rotor to the left). Insert 3/4" carriage bolts with hands up and attach 2-Blade Rotor Half (RB-42) **OPPOSITE** as shown in figure 1. Tighten into place 9 1/4" center to center of first Rotor.
3. Again rotate rotor shaft 1/2 turn backward and place 4-Blade Rotor Half (RB-44) **C** in the same maner as in #1 (blades included).

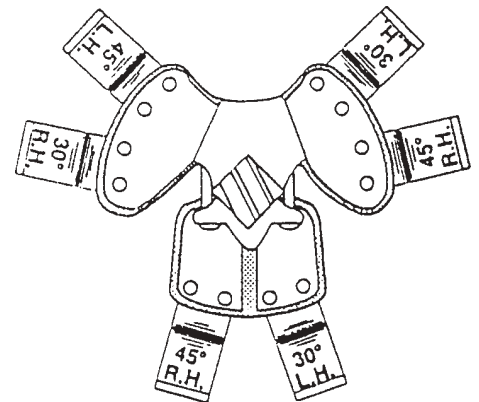

Figure 2

**NOTE:** Space this rotor and all succeeding rotors 9 1/2" center to center.

4. Repeat #2 for **D**. Repeat this sequence until rotors are all mounted. The last rotor should mount approximately 3 1/4" from the RH end plate.

**NOTE:** All rotors and blades in **A**, **C**, etc. are mounted as in Figure 2. All rotors and blades in **B**, **D**, etc. are mounted as in Figure 3.

Always measure center to center of rotor halves on same side of shaft. Blades may be either assembled in rotors in advance, or after rotors are in position as described.

**NOTE:** RH & LH blades are insignificant as long as blades in Figure 2 are mounted opposite blades in Figure 3. (Blades are not stamped for RH or LH.)

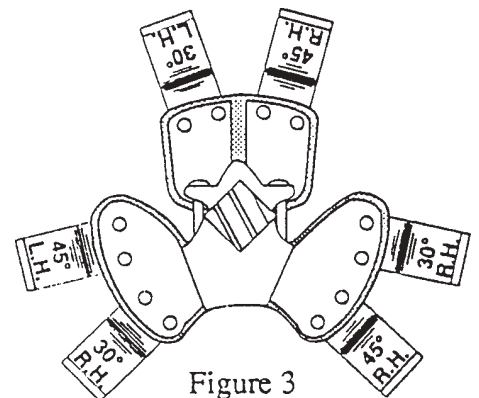

Figure 3



## Spike Rotor & Blade Assembly

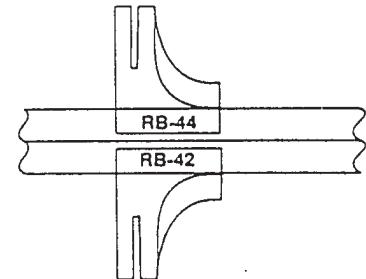
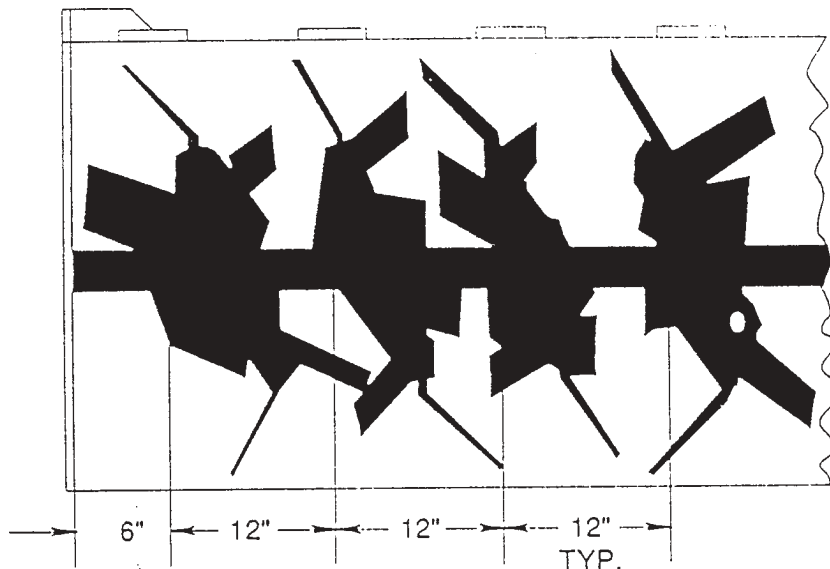

Figure 1

All rotors are mounted in this manner - from left to right.

1. Starting with the L.H. Rotor Assembly (above) with blades assembled as in figure 2, place a 4-Blade Rotor Half (RB-44) in position on top of the shaft (hub of rotor to the right). Position center of rotor approximately 6" from inside of housing end. Insert 3/4" carriage bolts with heads up and attach 2-Blade Rotor Half (RB-42) as shown in figure 1. Tighten into place.
2. Rotate shaft 1/4 turn backward (top blade toward you) and position 4-Blade Rotor Half (RB-44) B with blades assembled as in Figure 2 (Hub of rotor to the right). Insert 3/4" carriage bolts with hands up and attach 2-Blade Rotor Half (RB-42) as shown in figure 1. Tighten into place 12" from center to center of first rotor (see above).
3. Again rotate rotor shaft 1/4 turn backward and place 4-Blade Rotor Half (RB-44) in the same maner as in #1 (blades included).

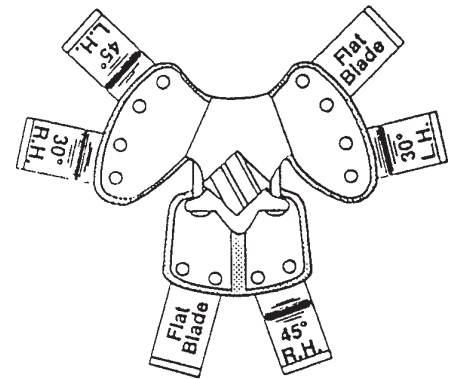

Figure 2

**NOTE:** Space this rotor and all succeeding rotors 12" center to center.

4. Repeat this sequence until rotors are all mounted. The last rotor should mount approximately 6" from the RH end plate (the hub of the last rotor must be reversed to the left).

**NOTE:** All rotors and blades are mounted as shown in figure 2 except the last rotor. The blades are mounted the same on the last rotor, but the hub is reversed as explained in #4. RH and LH blades are insignificant as long as the blades are mounted opposite each other as shown in figure 2. (Blades are not stamped RH or LH.)

Always measure center to center of rotor halves on same side of shaft. Blades may be either assembled in rotors in advance, or after rotors are in position as described.

## Assembly and Use of the Drawn Hitches

For SRB4079 (5 Belt Tillers) & SRB4081 (6 Belt Tillers)

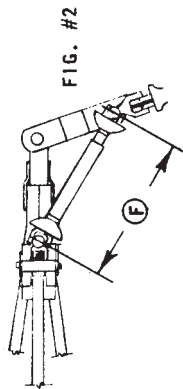

Do not allow telescoping shaft to "Bottom" at (F) or extend beyond limit of 36" w/RB-4079 or 40" w/RB-4081 at (A).

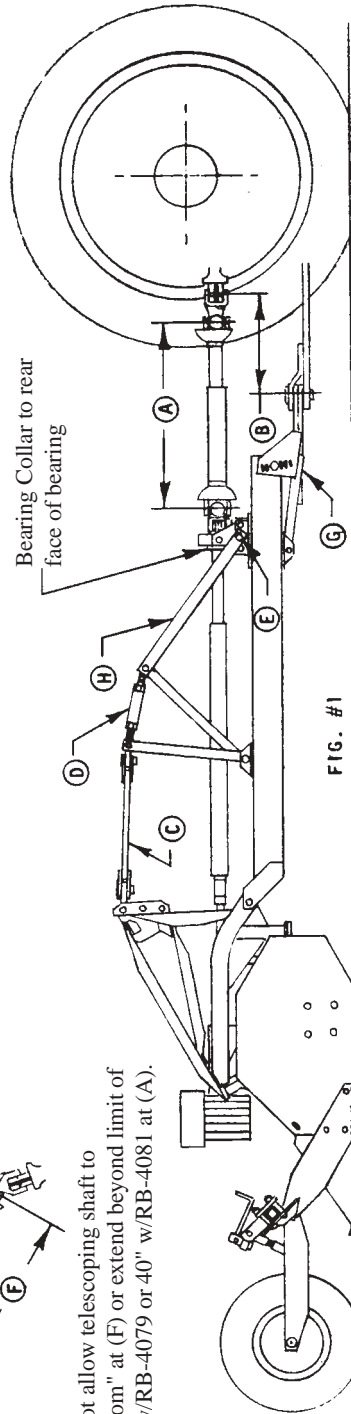

The SRB4079 and SRB 4081 drawn hitches are shipped with one-half section of universal joint assembly, which is to be attached to the tiller. The complete assembly furnished with the tiller is used between tractor and drawn hitch. The draw bar must extend a minimum of 16" between center line of pin and the end of tractor PTO shaft **B** before connecting tractor to drawn hitch. If this can be extended up to 18" to 19" on SRB4079 & 20" on SRB4081 it will allow for a greater turning angle before "bottoming" (see **F**, figure 2). If tractor dimension **B** is approximately 20" then shaft bearing on hitch at **E** should be in front position. If tractor dimension **B** is approximately 16" then shaft bearing should be in center position as shown.

- (1) Connect hitch to tractor draw bar.
- (2) Connect universal joint assembly after lubrication telescoping area.
- (3) Adjust height of frame at G until joint assembly is reasonably in line as shown.
- (4) If hydraulic cylinder is to be used, attach same to place of link C and retard to closed position.
- (5) Adjust turnbuckle D to bring tiller "level" with ground line as shown. If turnbuckle has insufficient travel, reposition bar H at E.
- (6) Before transporting tiller to the field, carefully turn tractor to right or left to determine maximum angle possible before reducing the dimension shorter. Approximately 24" are needed for the SRB4079, 28" for the SRB4081, 22" for the SRB4079 and 26" for the SRB4081. The universal joint assembly will bottom (see F, figure 2), and serious damage may result if forced further.
- (7) If hydraulic cylinder is not used at C tiller may be transported by rolling on the blades similar to a disc harrow. This should not be done on paved or graveled roadways.
- (8) When in the field again retard hydraulic cylinder to full closed position and adjust gauge wheels to attain desired tilling depth. This allows the operator to always return tiller to this working depth without guess work.
- (9) Recheck assembly for "levelness" with tiller position and "relevel" if necessary.

**We must EMPHASIZE that care must be used in making turns (see #6). We cannot honor warranty claims for any drive lines parts damaged by turning tractor at too great and angle.**

NOTE: Disengage PTO on turn over 300.

## Adjustment And Care of "V" Belt Drive

A belt drive was chosen for this Rotary Tiller as the simplest and safest means to protect tiller blades, gears, etc., as well as tractor drive from shock and overloads. When in proper adjustment, belts will not slip except when overloaded. Do not over-tighten.

### Belt Adjustment

NOTE: Do NOT use these spring bolt nuts for any adjustment. They must always be positioned at full depth as shown. Adjust drive sheave assembly by tensioning screw for all belt tension adjustment.



When starting a new tiller or tiller with a new set of replacement belts, the belt tension should be increased by several turns of the belt tension adjuster to allow for stretch and break-in. (See above paragraph.)

Re-check the belt tension indicator approximately every 10 to 15 minutes of tilling. This is especially important on wider tillers with the longer belts, which may stretch under load becoming too loose or may turn over. This may result in damaged belts. After two or three adjustments, belts are usually stretched to proper working length.

When replacing belts the need not all have the same code numbers. (See Chart Below.)

Belt Numbers	Matching Limit
81 to 150      use up to	2 Code Numbers*
151 to 285    use up to	3 Code Numbers*
* Code numbers must be consecutive. The longer codes representing the majority of belts in the set.	

The Idler System as used on the Northwest Rotary Tiller tends to keep a uniform fit around the sheaves even though belts tend to be somewhat different lengths. If a single belt becomes badly damaged, it should be cut away, or it may damage the balance of the set by breaking and becoming tangled between the belts and the idler assembly. The tiller may be operated with one less belt than a full set, UNLESS the tiller is operating to full capacity. However, it should not be necessary to install a complete new set should one or more belts become damaged. In line with the above information on matched belts, simply add the necessary replacement either new or used and tighten to proper setting.

## V-Belt Drive Trouble Shooting Checklist

PROBLEM	CAUSE	CORRECTION
<ul style="list-style-type: none"> <li>• <b>Belts slip</b></li> </ul>	<ul style="list-style-type: none"> <li>• Insufficient tension.</li> <li>• Overloaded tractor motor.</li> </ul>	<ul style="list-style-type: none"> <li>• Check tension setting.</li> <li>• Reduce tiller working depth.</li> </ul>
<ul style="list-style-type: none"> <li>• <b>Belts squeal</b></li> </ul>	<ul style="list-style-type: none"> <li>• Insufficient tension.</li> <li>• Overloaded tractor motor.</li> </ul>	<ul style="list-style-type: none"> <li>• See above. Some slippage is natural in heavy, rough, or rocky soils. This is no problem as long as belts do not become overheated.</li> </ul>
<ul style="list-style-type: none"> <li>• <b>Rapid belt wear</b></li> </ul>	<ul style="list-style-type: none"> <li>• <b>Excessive slippage.</b></li> <li>• Worn idlers &amp; sheaves.</li> <li>• Belts turning over and so operated.</li> <li>• Idler out of proper position because of improper post or bent or broken post bracket.</li> </ul>	<ul style="list-style-type: none"> <li>• Check for proper tension.</li> <li>• <b>Do not overload.</b></li> <li>• Keep tractor to full recommended speed.</li> <li>• Check chart for proper post.</li> <li>• Do not re-weld a broken post bracket, as it cannot be held to its proper shape.</li> </ul>
<ul style="list-style-type: none"> <li>• <b>Belts turn over</b></li> </ul>	<ul style="list-style-type: none"> <li>• Belt damage during installation.</li> <li>• Improper tension, particularly when encountering shock loads.</li> <li>• Rusty sheave grooves and or sticky cover on new belts.</li> <li>• Tiller not "level" with tractor causing excessive vibration of Tiller drive.</li> <li>• Backing Tiller with blades touching ground.</li> </ul>	<ul style="list-style-type: none"> <li>• Check for proper tension.</li> <li>• Roll belt or belts back into proper position and over-tighten belts to restretch.</li> <li>• After a few hours operation readjust to proper tension. (See Adjustment and Care, Page 5)</li> <li>• If this extra tension does not prevent belts turning over, reverse position in groove, that is reverse ends or vertical positions.</li> <li>• Check Tiller Assembly</li> <li>• Check sheaves for bent flange or "excessive" eccentricity.</li> <li>• Level Tiller</li> </ul>
<ul style="list-style-type: none"> <li>• <b>Belt Breaks</b></li> </ul>	<ul style="list-style-type: none"> <li>• Shock or heavy starting loads.</li> <li>• Belt damaged during installation.</li> <li>• Foreign objects in drive.</li> </ul>	<ul style="list-style-type: none"> <li>• Apply proper tension.</li> <li>• Install new belts properly.</li> <li>• Keep shrouds in place.</li> </ul>

Never use belt dressing. When installing new belts do not force or pry belts over sheaves. Reduce the drive center distance. If one belt is tighter or looser on top than balance when first installed, you will find that it will be the opposite on the bottom. As soon as it has been operated a few moments the tension will be equalized

**WARNING:** Thru improper adjustment or severe overload the belt sheaves may get overheated due to excess slippage. When this occurs, do not stop tiller drive. Simply stop tractor travel and keep PTO engaged while allowing the belts and sheaves to cool down or charring of belts may result.

**DO NOT REVERSE TRACTOR WITH TILLER BLADES TOUCHING GROUND OR LOADING RAMP. DAMAGED BELTS MAY RESULT.**

## Trouble Shooting

PROBLEM	CAUSE	CORRECTION
<b>Tiller runs unevenly and seems to jump forward and up and down.</b>	<ul style="list-style-type: none"> <li>• Cutting edge of blade reversed</li> <li>• Blades in line instead of in spiral.</li> <li>• PTO Universal Joints out of line.</li> <li>• PTO Universal Joints not operating at same angle.</li> <li>• Tractor traveling too fast over ground for speed of rotor which causes blades to take too large a "bite".</li> </ul>	<ul style="list-style-type: none"> <li>• See page 3.</li> <li>• See page 3.</li> <li>• See page 4.</li> <li>• See page 4.</li> <li>• Reduce tractor speed over ground but keep up motor speed by shifting to lower gear.</li> <li>• Change V-Belt sheave.</li> <li>• See page 8.</li> </ul>
NOTE: In most heavier soils it is not possible to use tractor with "free wheeling" type of transmission unless it is equipped with a selection of speed gears that bypass the "free wheeling action" since the tiller is usually pushing the tractor and if not held back to the proper ground speed, too large "bite" of the blades results.		
<b>Tiller works to desired depth but does not cut off all weeds, etc.</b>	<ul style="list-style-type: none"> <li>• Too fast ground speed or not proper size V-Belt sheaves.</li> <li>• Blades set too far apart.</li> </ul>	<ul style="list-style-type: none"> <li>• See page 8-12.</li> <li>• See page 3.</li> </ul>
<b>Requires too much power.</b>	<ul style="list-style-type: none"> <li>• Blades on backwards.</li> <li>• Operating too great a depth for size of tractor.</li> <li>• Slipping belts. Contrary to popular opinion, a slipping belt uses up more power producing a lower RPM than a tight belt holding the Tiller blade rotor up to proper speed. <b>DO NOT TIGHTEN BELTS</b> beyond instructions on Idler Decal.</li> </ul>	<ul style="list-style-type: none"> <li>• See page 3.</li> </ul>
<b>Tiller tends to "crab" to right or left.</b>	This may happen on the wider tillers in offset position on hillside or uneven ground, particularly if ground is hard or heavy	<ul style="list-style-type: none"> <li>• Keep guage wheels carrying full load. It may be necessary to move Guage Wheels to rear or sides, if front mounted.</li> <li>• See page 5</li> </ul>
<b>Tractor is rolled or pushed ahead when Tiller touches the ground.</b>	It must be remembered that the action of the tiller's blades are much like the old spade lugs used on tractor wheels before the advent of the rubber tire. If the tractor was held back, the lugs dug up or "tilled" the soil. Likewise, if the Tiller is not "held back" it acts like a tractor and travels, using the blades for traction.	<ul style="list-style-type: none"> <li>• Have tractor in proper gear (slower ground speed) or if tires are skidding, set Tiller shallower.</li> </ul>
<b>Tiller will not properly penetrate soil.</b>	<ul style="list-style-type: none"> <li>• Ground too dry and hard. (Remember that a tiller has approximately the same resistance to penetrating hard ground as a mouldboard plow).</li> <li>• Blades on backwards.</li> <li>• Guage Wheels improperly set.</li> </ul>	<ul style="list-style-type: none"> <li>• See page 3</li> </ul>
<b>Belts slipping though properly adjusted.</b>	This may occur if tractor cannot keep up proper speed and starts "lugging".	<ul style="list-style-type: none"> <li>• Change depth and/or ground speed.</li> <li>• Check for proper sheave size.</li> </ul>

**Sheave, Belt & Idler Post Chart**

Tiller Size	Sheave Diameters			Center of Drive Shaft to L.H. End of Frame 'A'	Belt Size	Idler Post				
						540 PTO RPM			1000 PTO RPM	
	No. Belts					No. Belts				
	10	12	15			4	5	6	5	6
48"	10	12		22	81	F				
60"-O	10	12		23 1/4	81	F	K			
60"-C	10	12		29	96	H	B	L	E	
60"-C		12-12			105				C	
60"-C	10		15	27 1/4	105		A			
72"-O	10		15		96					N
72"-O		12	15		105			N		
72"-O	10	12			81	F	K			
72"-C	10	12			112	J	D		C	S
72"-C	10		15	34 1/4	112	J	D	X		S
72"-C		12-12			120		C	S	C	S
72"-C		12	15		120		C	U		S
84"-O	10	12			96	H	B	Y	E	X
84"-O	10		15		96		A			
84"-O		12	15		112		A			X
84"-C	10	12			120	J	D	U	C	S
84"-C		12-12			120				D	
84"-C	10		15	43 1/2	128	G	D	U		S
84"-C		12	15	41 1/2	128		E	U		R
96"-O	10		15		112					U
96"-O	10	12			118	G	D		C	
96"-C	10		15	47	136	G	D	R		S
96"-C		12	15	45 1/2	136		E	S		S
96"-C			15-15		144					U
108"-C	10	12			144		D		C	
108"-C		12	15		158			U		V
108"-C	10		15		144		E	R		V
108"-C			15-15		158			U		V
120"-C	10		15		120					S
120"-C	10	12			158		E		C	
120"-C	10		15	61 1/2	162		E	R		V
120"-C		12-12			162			U		U
120"-C		12	15		162			U		V
120"-C			15-15		162			R		R

**Sheave, Belt & Idler Post Chart**

Tiller Size	Sheave Diameters			Center of Drive Shaft to L.H. End of Frame 'A'	Belt Size	Idler Post				
						540 PTO RPM			1000 PTO RPM	
	No. Belts					No. Belts				
	4	5	6			5	6			
132"-C	10	12			173				C	V
132"-C		12-12			173			V		V
132"-C	10		15		173	G	E			V
132"-C			15-15		173					V
132"-C		12	15		173			V		V
144"-C		12-12			180			V		V
144"-C		12	15		180		C	V		V
144"-C	10		15		180		C			V
144"-C			15-15		195					U
156"-C	10	12			195				C	
156"-C	10		15		195		C	W		V
156"-C		12	15		195			W		V
168"-O		12-12			195			W		W
168"-O		12	15		195					V
168"-C	10	12			195				C	
168"-C		12-12			210		C	T	C	T
168"-C	10		15	84 1/2	210		C	S		T
168"-C		12	15		210		C			T
168"-C			15-15		210			V		V
180"-C	10		15		225				C	T
180"-C		12	15		225					T
192"-C	10		15		225					T
192"-C		12	15		240					T
204"-C	10	12			240					T
204"-C	10		15		240					T
204"-C		12	15		240					T
216"-O										
216"-C		12	15		225					T
228"-O										
228"-C										
240"-C		12	15		285					T

## Vineyard Sheave, Belt & Idler Post Chart

Tiller Size	Sheave Diameters			Center of Drive Shaft to L.H. End of Frame 'A'	Belt Size	Idler Post				
						540 PTO RPM			1000 PTO RPM	
	No. Belts					No. Belts				
	10	12	15			4	5	6	5	6
72"	10		15		90		A			
72"	10	12			81		K			
72"	10	12			81	F	K			
72"		12-12								
72"		12	15							
84"	10		15		90		A			
84"	10	12			90		B		E	
84"		12-12			90		B			
84"		12	15		96		A			
90"	10	12			96		B			
96"	10		15		96		B			U
96"	10	12			96		B			
96"		12-12								
96"		12	15		105			N		U
108"	10		15		112					
108"	10	12			105					
108"		12-12								
108"		12	15		112			U		U
120"	10		15		128					S
120"	10	12								
120"		12-12								
120"		12	15		128					S
132"		12	15		136					S
144"		12	15		162					V
168"		12	15		180					V

**Sheave Combinations**

To change DRIVE or DRIVEN sheave	From	To	(B) would move to the RIGHT approx.
To change	15	12	1 3/4"
To change	15	10	3 3/4"
To change	15	8 1/2	5"
To change	12	10	7/8"
To change	12	8 1/2	2 1/2"
T change	10	8 1/2	1/2"

Note: If larger sheaves are substituted for smaller sizes (B) would move to the left

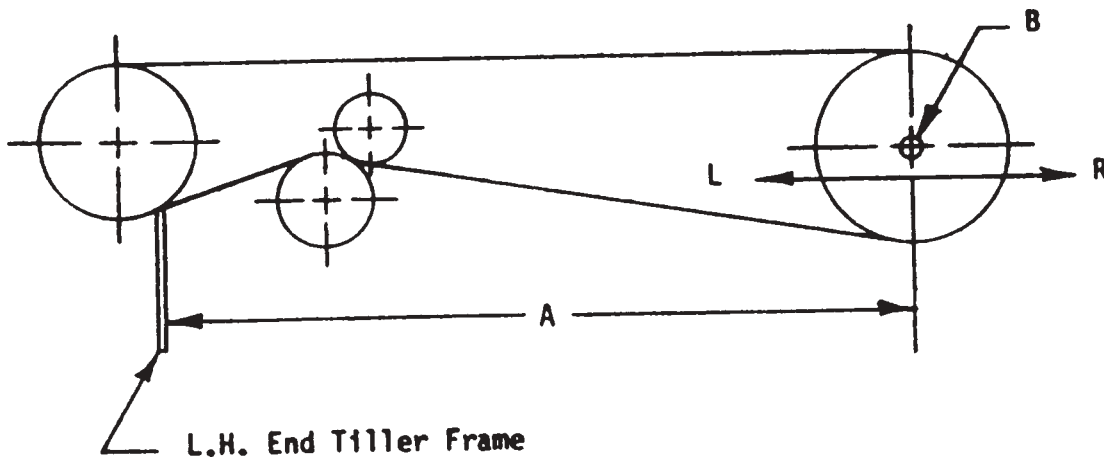

## Sheave Combinations

**Proper Motor Speed** - In most conditions operate motor to give full 540 (or 1000) RPM at tractor PTO. If speed is reduced, particularly from overload, excessive belt slippage and pulsation will result.

**Before lifting tiller** at end of field, it is best to either reduce motor speed or disengage tractor PTO. The integral hitch linkage on most tractors tends to raise the tiller in an arc instead of a "level" position, thereby causing considerably more angle to the front of the tractor PTO universal joint than to the rear of the tiller joint. This creates excessive vibration at full motor speed.

**Tractor Ground Speed** - To determine the best ground speed to use, start tractor in low gear, then try second, etc. (See below).

**NOTE:** It will take more horsepower at the higher ground speeds to produce a somewhat courser tilth. If a finer tilth is desired at the faster ground speed, a smaller **driven** sheave (on the 540 RPM drive) or a larger **driving** sheave (on the 1000 RPM drive) will be required. For fine seed beds, it may be desirable to use top speeds at slower ground speeds.

### PROPER SIZE SHEAVES FOR DIFFERENT BLADE ROTOR SPEEDS

	Drive Sheave Size	Driven Sheave Size	Produces Approx. RPM of Blade Rotor Shaft	Recommended Max. Ground Speed for Average Tilling
<b>On Standard Drive Tillers used with 540 RPM PTO Speed</b>				
"A" & "B" Drive	Standard 12"	10"	174	2 MPH Max.
	12"	12"	152	1 1/2 MPH Max.
	15"	12"	190	2 1/4 MPH Max.
	15"	10"	228	3 MPH Max.
<b>On Standard Drive Tillers used with 1000 RPM PTO Speed</b>				
"B" Drive	Standard 10"	12"	235	3 MPH Max.
	12"	12"	282	4 MPH Max.
	12"	10"	346	5 MPH Max.
<b>Heavy Duty Drive used with 540 RPM PTO Speed</b>				
"C" Drive	Standard 15"	15"	144	1 1/2 MPH Max.
	15"	12"	181	2 1/2 MPH Max.
	15"	10"	218	3 1/4 MPH Max.
<b>Heavy Duty Drive used with 1000 RPM PTO Speed*</b>				
"C" Drive	Standard 10"	15"	192	2 3/4 MPH Max.
	12"	15"	231	3 1/4 MPH Max.
	15"	15"	289	4 MPH Max.
	15"	12"	360	5 MPH Max.
<b>Extra Heavy Duty Drive 1000 RPM PTO Speed</b>				
"D" Drive (6-Belt)	Standard 10"	15"	160	2 MPH Max.
	12"	15"	190	2 1/4 MPH Max.
	15"	15"	238	3 MPH Max.
	15"	12"	298	4 MPH Max.
	15"	10"	357	5 MPH Max.

\* On larger tractors the 1000 RPM PTO Speed is recommended if tractor is so equipped, since this greatly increases the efficiency of the "V" belt drive.

**Blade Depth Variations**

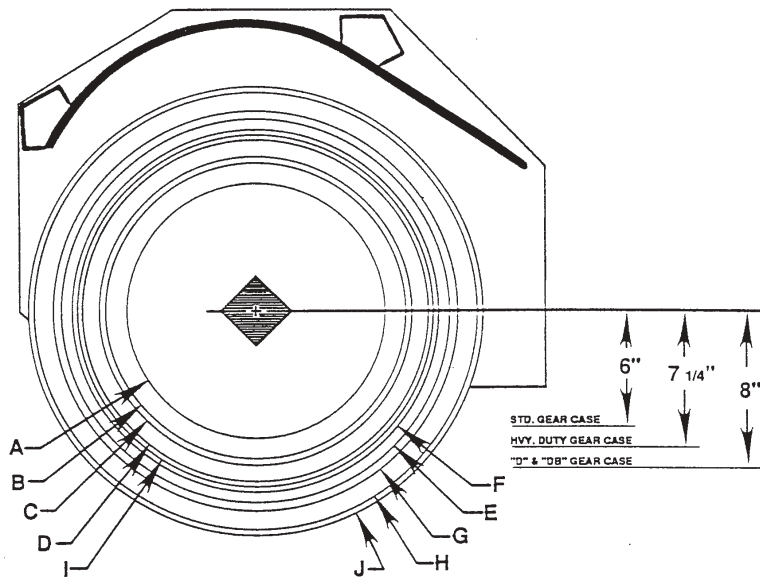

	ROTOR & "L" BLADE* ASSEMBLY	RAD.
A	R-9A Inner Position	8 1/4"
B	R-9A Outer Position	9 5/8"
C	R-50 Inner Position	10"
D	R-50 Middle Position	11 1/4"
E	R-50 Outer Position	12 1/2"
F	D-150 Inner Position	11 3/4"
G	D-150 Middle Position	13"
H	D-150 Outer Position	14 1/4"
I	RB-42 & 44 or RB-62 & 64 Standard Position	11 1/2"
J	D-82 & 84 Standard Position	14 3/4"

\* Add 1 7/8" to all dimensions for Saber Blades.  
 Note: Sabre Blades are mounted only on RB-62 & RB-64 rotors.

\*\* Add 1 3/8" to all dimensions for Speed Spike Blades.  
 These blades may be mounted on any type rotor.

NOTE: Low profile housing - 14" radius maximum  
 High clearance housing - 16 1/2" radius maximum

## Gear Case "Wobble" Correction

fig. A



1. Raise tiller to transport position.
2. Stop tractor motor and disengage tractor PTO.
3. Place Dial Indicator from endplate to outside of gearcase. It is important that the dial indicator is mounted in direct line with the center of the rotor shaft. *See fig.A.*
4. Grip drive belt by hand and rotate rotor shaft forward until dial indicator is at highest point.
5. Use torch with large tip to heat to yellowish red a strip between the first and second rotor. *See fig.B.* Heat between frame and first rotor as a last resort only. (This should be a small spot across the front face of the rotor shaft or across the corners.) Allow to cool and if necessary heat another spot 1 1/2" to 2" away and recheck. Repeat until dial indicator shows approximately .005 and .010 difference since this may be accepted as normal with no service problem resulting.

fig. B



fig. C



Note: Northwest Tiller suggests the use of propane gas to heat shaft up. Propane Gas burns hotter and is less dangerous than other fuels. The heat should be hot and fast with as small a spot as possible to achieve the best results. *See fig.C.* On the flat the heated spot should be about the size and shape of a silver dollar. *See fig.D.* On the corner it should be diamond shaped, about 2" long and 1" deep. *See fig.E.*

fig. D

The Flat

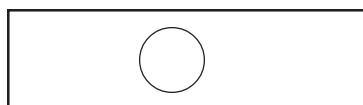
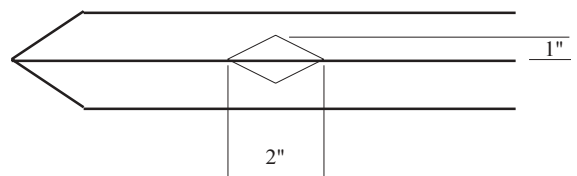
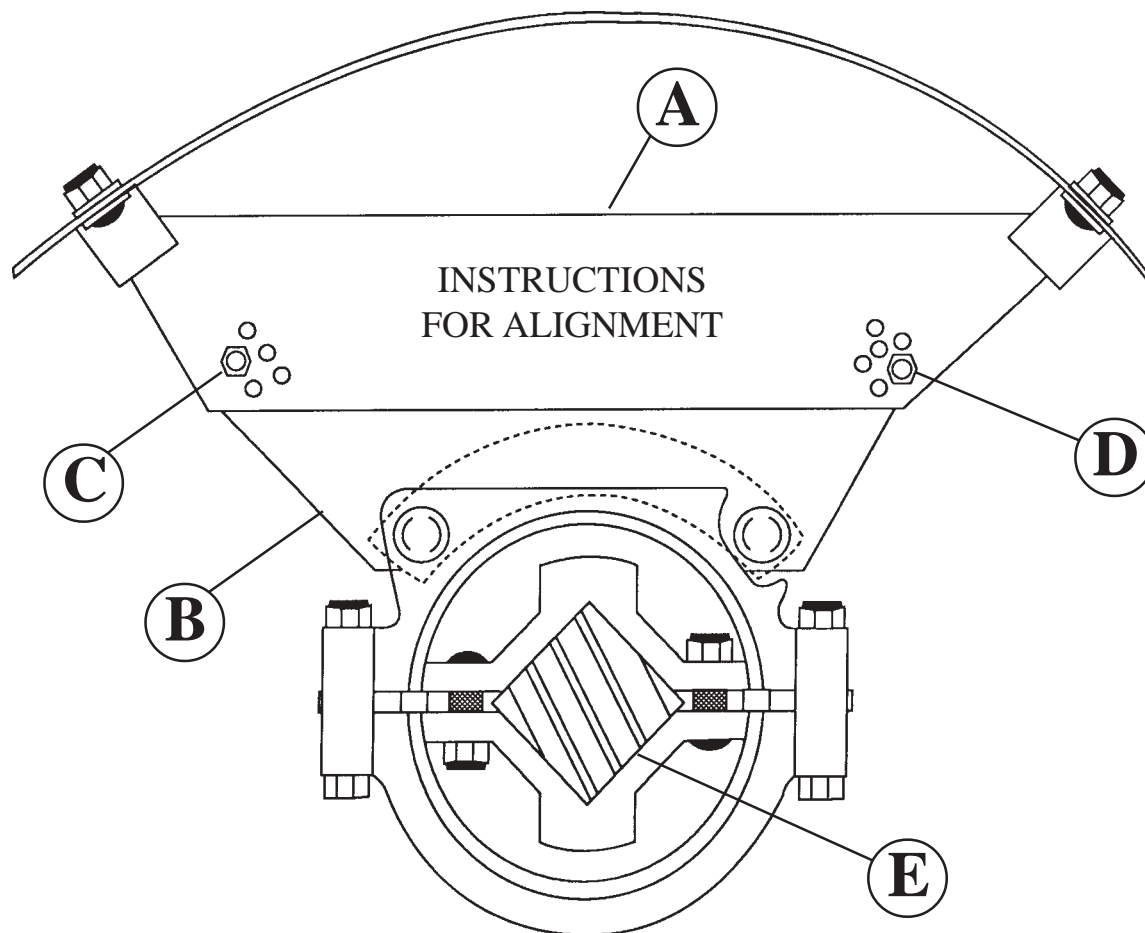

fig. E

The Corner



## Center Bearing



With full sag in the rotor shaft (E), push bearing housing to a forward and up position and insert bolts at (C) and (D) (not necessarily on the holes shown in print) and tighten in place. **Do not force bearing up.** If holes do not match, use next lower position. Since, when tilting, the rotor shaft tends to stay in the down or sagging position, and has a tendency to "crawl" ahead in its effort to push the tractor, the location of the bearing as suggested should prevent excessive wear on the bearing. Tighten bearing sleeve to shaft after properly "centering" it with the outer hub. **(Do not over tighten as breakage may occur.)**

We further suggest that if excessive wear should appear in any direction, a re-positioning of the flange (B) in upper support (A) should be done. This bearing is used **not to hold the shaft in a normal position**, but to contain it in as near its natural **working position** as possible to prevent "whipping" which otherwise might occur

The 3/8" + clearance in these bearings is necessary to allow maximum freedom of shaft, and as a result, a slight "knocking" may occur which is harmless.

### Center Bearing Adjustment

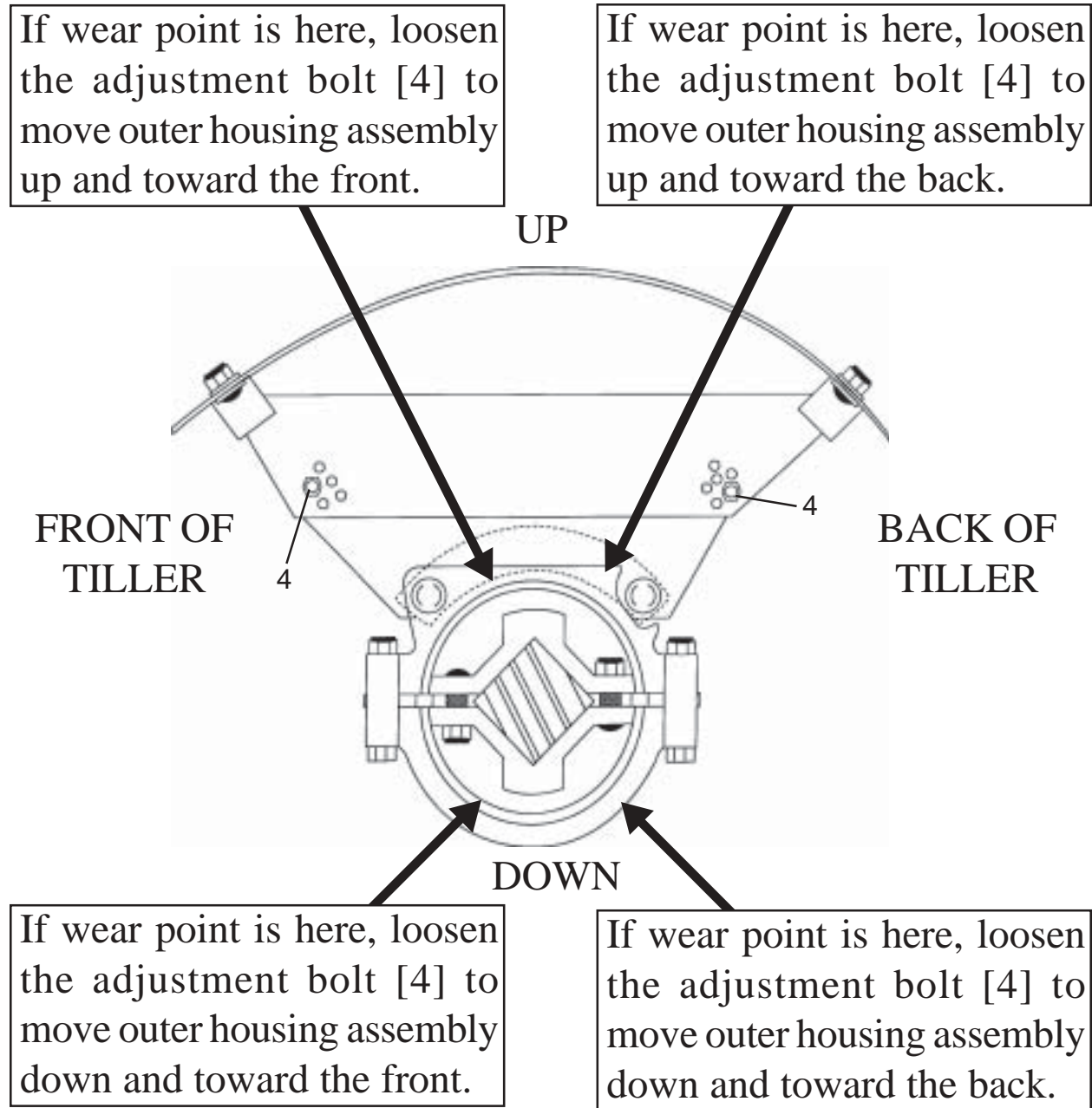

## Northwest Torque Tubes for all Gear Cases

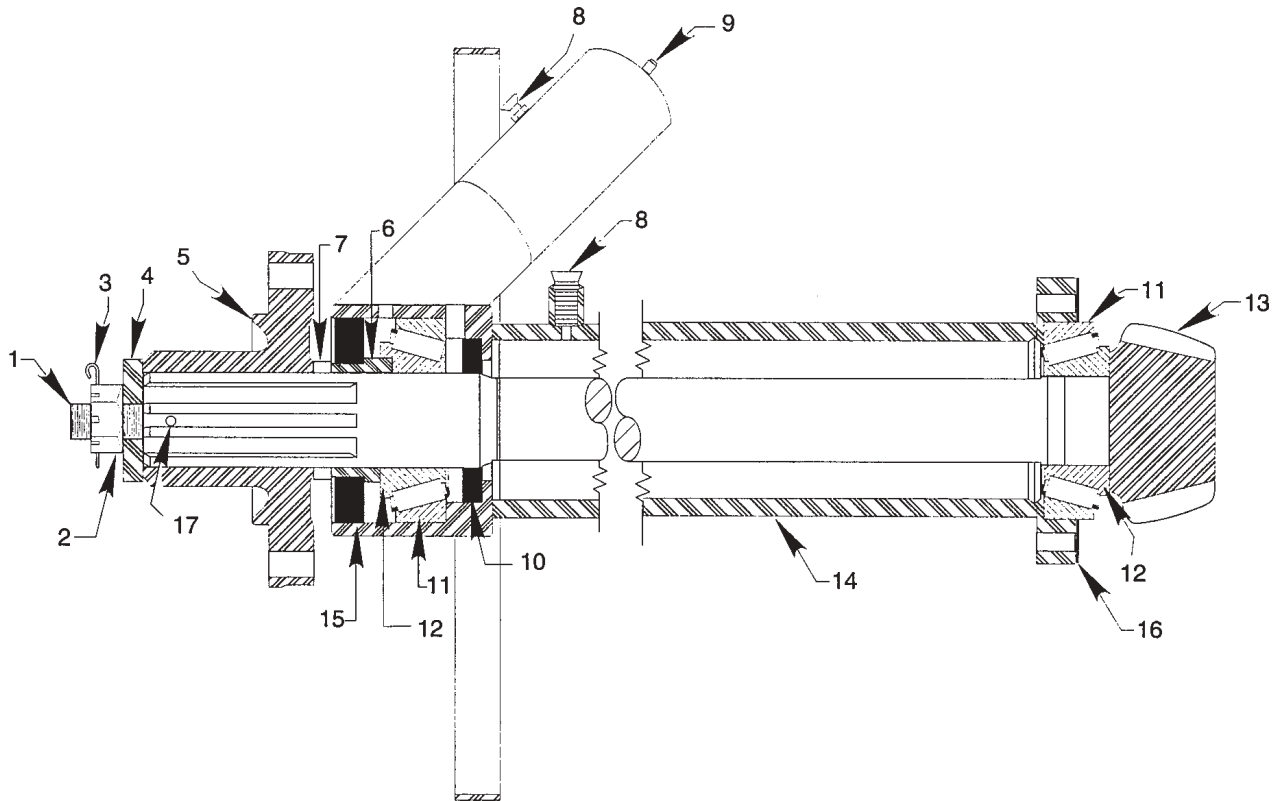

## IMPORTANT

The preload on item number 4 shown above is set at the factory. However, it is very important to periodically check the preload on item 4 and retighten as necessary to maintain preload on bearings in torque tube. Tightening is necessary when item number 4 can be moved by turning. Set Preload to 180 inch pounds.

**Relative Position of Offset - Northwest Tillers to Center Line of Tractor**

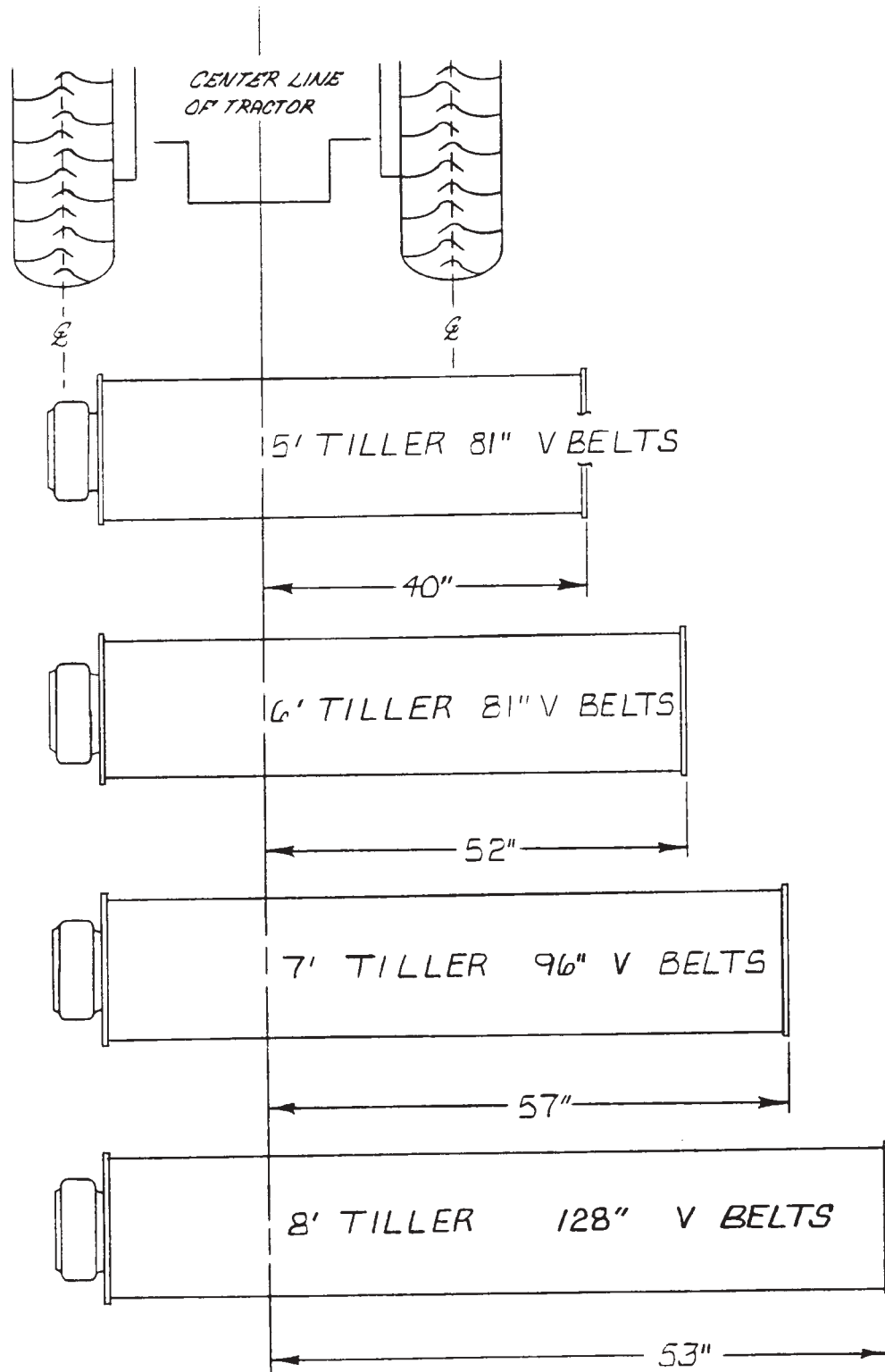

## Dual Drive "D" Tiller Belt Adjustment Procedure

A belt drive was chosen for this Rotary Tiller as the simplest and safest means to protect tiller blades, gears, etc., as well as tractor drive from shock and overloads. When in proper adjustment, belts will not slip except when overloaded. Do not over-tighten.

### Belt Adjustment

NOTE: Do NOT use these spring bolt nuts for any adjustment. They must always be positioned at full depth as shown. Adjust drive sheave assembly by tensioning screw for all belt tension adjustment.



When starting a new tiller or tiller with a new set of replacement belts, the belt tension should be increased by several turns of the belt tension adjuster to allow for stretch and break-in. (See above paragraph.)

Re-check the belt tension indicator approximately every 10 to 15 minutes of tilling. This is especially important on wider tillers with the longer belts, which may stretch under load becoming too loose or may turn over. This may result in damaged belts. After two or three adjustments, belts are usually stretched to proper working length.

Prior to 1991

- (1) Loosen stabilizer arm at C.
- (2) Adjust RIGHT HAND belts to match indicator instructions - same as step 1.
- (3) Adjust SHORT belts at D - see below
- (4) Retighten stabilizer arm which was loosened in step 1.
- (5) Check both right hand belt stabilizer idlers to insure all belts ride evenly and freely in the grooved idlers. Adjust if necessary.

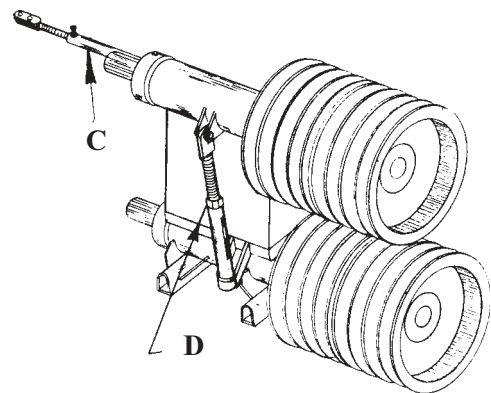

**Belts - Dual Drive "D" Tillers**

Length	No. Used	Size	Driven	Drive	Post
240" (20')	4	C-285	12	15	DD-H
240" (20')	4	C-300	12	15	DD-J
240" (20')	5	C-75*	15	15	
228" (19')	4	C-270	12	15	DD-H
228" (19')	4	C-285	12	15	DD-J
228" (19')	5	C-75*	15	15	
216" (18')	4	C-255	12	15	DD-H
216" (18')	4	C-270	12	15	DD-J
216" (18')	4	C-75*		12	
216" (18')	8	C-270/C-75*	15	15	
204" (17')	4	C-255	12	15	DD-H
204" (17')	4	C-255	12	15	DD-J
204" (17')	5	C-75*	15	15	
192" (16')	4	C-240	12	15	DD-H
192" (16')	4	C-240	12	15	DD-J
192" (16')	5	C-75*	15	15	
180" (15')	4	C-240 (RH Side)	12	15	DD-H
180" (15')	4	C-225 (LH Side)	12	15	DD-J
180" (15')	5	C-75*	15	15	
168" (14')	4	C-210	12	15	DD-H
168" (14')	4	C-210	12	15	DD-J
168" (14')	5	C-75*	15	15	

\* 1988 & earlier models - use C-60 belts, 12 Driven & 12 Drive

---



---

**Belts - dual drive "D" Tillers - 6 Belt Drive System**

Length	No. Used	Size LH / RH	Driven	Drive	Post LH / RH
240" (20')	6	RT-3285 / RT-3297	RB2615	RB2612	RB-123 / L-101
228" (19')	6	RT-3270 / RT-3285	RB2615	RB2612	RB-123 / L-101
216" (18')	6	RT-3255 / RT-3285	RB2615	RB2612	RB-123 / L-101
204" (17')	6	RT-3250 / RT-3270	RB2615	RB2612	RB-123 / L-101
192" (16')	6	RT-3240 / RT-3255	RB2615	RB2612	RB-123 / L-101
180" (15')	6	RT-3225 / RT-3250	RB2615	RB2612	RB-123 / L-101
168" (14')	6	RT-3210 / RT-3235	RB2615	RB2612	RB-123 / L-101
156" (13')	6	RT-3195 / RT-3210	RB2615	RB2612	RB-123 / L-101
144" (12')	6	RT-3180 / RT-3195	RB2615	RB2612	RB-123 / L-101